

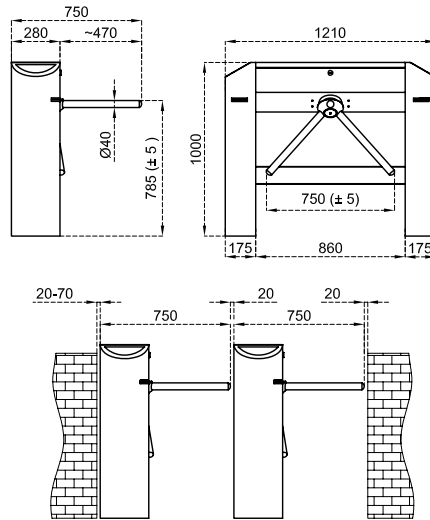







Dimensions (mm)



Technical Features

Place of Use	Indoors, outdoors	
Operating Temperature, Humidity	-20°C/+68°C (opt. -50°C with heater positive), RH %95 non-condensing..	
Operating Intensity	%100, 7/24 use.	
Body Features	Material	: 304 grade (opt. 316 grade) stainless steel.
	Finishing	: Orbital brushed matt (opt. electrostatic powder coating on stainless steel).
Arms	Automatic Drop (Retractable) Arm	: Standard
	Material	: Ø40x1,2 mm 304 grade (opt. 316 grade) stainless steel, one by one demountable.
	Finishing	: Satine brushed (opt. orbital brushed matt, electrostatic powder coating on stainless steel).
Indicators	Side Status /Direction Indicators	:   LED, standard.
	Top Passage Indicator	:     LED, standard.
Power	Operating Voltage	: 110/220V AC 50/60 Hz. (%±10), 24V DC.
	Consumption	: ~9W at stand-by, max ~44W (varies according to the options and accessories used).
Operating Modes	System operates bi-directionally (entry-exit). Operation modes can be changed through dip switch, PC and/or android app. Entry - exit controlled Entry controlled, exit free Entry free, exit controlled Single input both directions use Entry - exit free	
Operating System	Electromechanical motorized operation (opt. electromechanical manual operation).	
Control System	All functions, parameters and operating modes can be changed through the control board (microprocessor controlled), PC (Windows) and/or android app. Firmware can be updated. All past function updates and changes are kept in the server and records can be traced. All inputs are opto-coupler protected. Controllable by dry contact (ground control). Compatible with all kinds of access control device. Optional RS232, RS485 or TCP/IP module is available.	
Flow Rate	Capacity of mechanism (manual)	: Max. 82 cycle/min. Nominal : ~30 pass/min.
	Capacity of mechanism (motorized)	: Max. 75 cycle/min. Nominal : ~25 pass/min. (Passage rate can change depending on the access control system utilized)
Emergency Mode	System allows free passage (entry-exit) in both directions by the automatic drop arm (fail safe). Works compatible with fire warning and similar systems. At the end of an emergency situation, system returns to its normal operating mode.	
Power-off Situation	System allows free passage (entry-exit) in both directions by the automatic drop arm (fail safe). Optionally, can be set (fail secure) as; entry-exit locked, entry free-exit locked, or entry locked-exit free. Free passage in chosen direction by manual override key in fail secure option is available.	
Weight	~48 kg	
Optional Features and Accessories	Wireless remote control (receiver-transmitter), manual control, manual override key (with fail secure option), coin slot and coin box, single/multiple intelligent coin/token slot and box, counter (with/without reset), card reader mounting bracket, photocell alarm sensor, passage completion sensor, contactless passage sensor, heater positive, top lid weight sensor, bottom plate, battery back-up, 316 grade stainless steel, RS232-RS485-TCP/IP modules, limiter, electrostatic powder coating on stainless steel, motorized card collector unit and card collection box.	

