

Dimensions (mm)

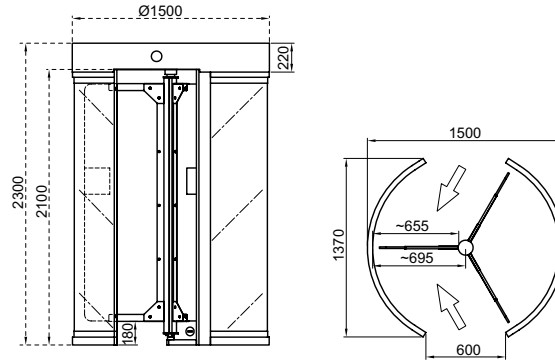

Technical Features

Place of Use	Indoors (opt. outdoors)	
Operating Temperature, Humidity	-20°C/+68°C (opt. -50°C with heater positive), RH %95 non-condensing.	
Operating Intensity	%100, 7/24 use.	
Body / Wing Features	Built on stainless steel main carrier beams, supported with box beams on sides, contains rounded glass walls, protecting top lid, mechanical compartment side panels and completely closed ceiling. The mechanics compartment is accessible from the ceiling. Contains three-wings rotor (120°).	
	Body	304 grade (opt. 316 grade)* stainless steel body and 4+4 mm laminated glass walls.
	Wings	12 mm tempered glass mounted on 304 grade (opt. 316 grade)* stainless steel rotor.
	(*) Finishing : Orbital brushed matt.	
Indicators / Illumination	Status - Direction Indicators :	LED, standard/LED passageway illumination standard.
Power	Operating Voltage	: 110/220V AC 50/60 Hz. (%±10), 24V DC.
	Consumption	: ~14W at stand-by, max ~50W (varies according to the options and accessories used).
Operating Modes	System operates bi-directionally (entry-exit). Operation modes can be changed through dip switch, PC and/or android app.	
	Entry - exit controlled	Entry controlled, exit free Entry free, exit controlled
	Single input both directions use	Entry - exit free
Operating System	Electromechanical manual operation (opt. electromechanical motorized operation).	
Control System	All functions, parameters and operating modes can be changed through the control board (microprocessor controlled), PC (Windows) and/or android app. Firmware can be updated. All past function updates and changes are kept in the server and records can be traced. All inputs are opto-coupler protected. Controllable by dry contact (ground control). Compatible with all kinds of access control device. Optional RS232, RS485 or TCP/IP module is available.	
Flow Rate	Passage capacity (manual)	: max. 30 cycle/min. Nominal : ~20 pass/min.
	Passage capacity (motorized)	: max. 20 cycle/min. Nominal : ~15 pass/min. (nominal passage rate can change depending on the access control system utilized)
Emergency Mode	System allows free passage (entry-exit) in both directions (fail safe). Works compatible with fire warning and similar systems. At the end of an emergency situation, system returns to its normal operating mode.	
Power-off Situation	System allows free passage (entry-exit) in both directions (fail safe). Optionally, can be set (fail secure) as; entry-exit locked, entry free-exit locked, or entry locked-exit free. Free passage in chosen direction by manual override key in fail secure option is available.	
Weight	~560 kg	
Optional Features and Accessories	Motor driven unit, wireless remote control (receiver-transmitter), manual control, manual override key (with fail secure option), counter (with/without reset), card reader mounting bracket, passage completion sensor, contactless passage sensor (for motorized models), heater positive, bottom plate (standard or for forklift handling), battery back-up, 316 grade stainless steel, RS232-RS485-TCP/IP modules, limiter.	

